

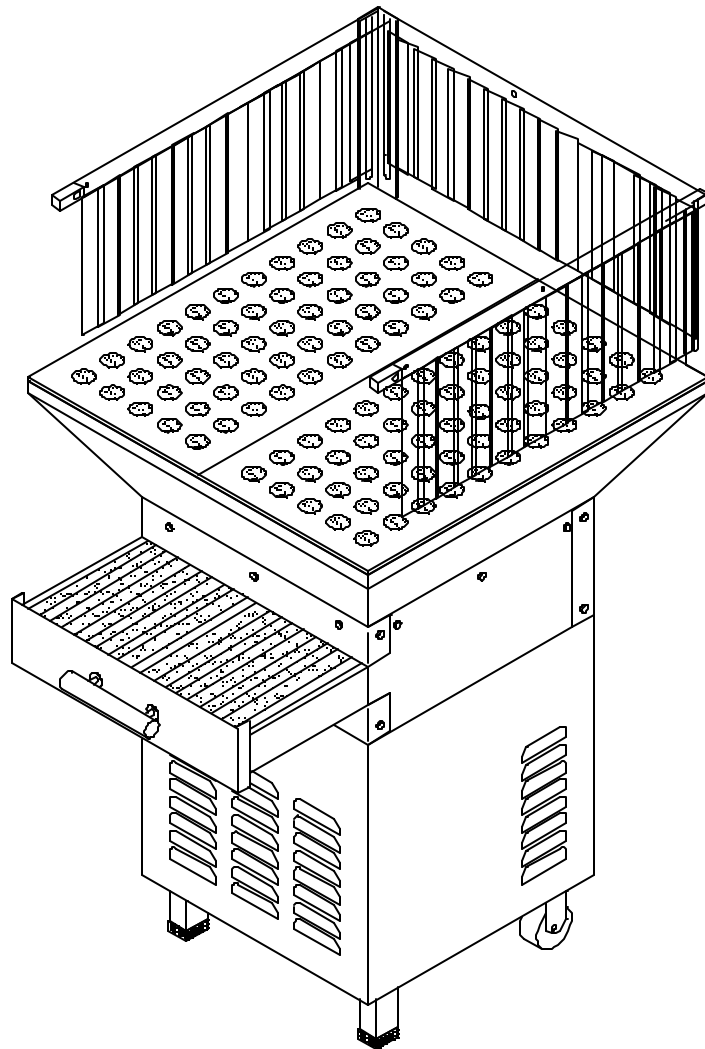

# Instruction Manual

## **Model: SDT-600**



## **EC DECLARATION OF CONFORMITY**

- According to the following EC Directive
- Machinery Directive : 98/37/EEC.
  - EMC Directive : 89/336/EEC.
  - Low Voltage Directive : 73/23/EEC.

### **DOWN-DRAFT TABLE**

**Model: SDT-600**

Provided that it is used and maintained in accordance with the generally accepted codes of good practice and the recommendations of the instruction manual, meets the essential safety and health requirements of the Machinery Directive, EMC Directive, and the EC Low Voltage Directive.

For the most specific risks of this machine, safety and compliance with the essential requirements of the Directive has been based on elements of:

- the European Standard EN 292-1 : 1991 - Safety of machinery –Basic concepts, general principles for design – Part 1: Basic terminology, methodology.
- the European Standard EN 292-2 : 1991 - Safety of machinery Basic concepts, general principles for design – Part 2: Technical principles and specifications.
- the European Standard EN 60204-1 : 1997 - Safety of machinery – Electrical equipment of machines – Part 1: General requirements.
- the European Standard EN 55014 : 1993 –Limits and methods of measurement of radio interference characteristics of electrical motor-operated and thermal appliance for household and similar purpose electrical tools and similar electric apparatus.

## Model Designation & Specification

<b>Model</b>	<b>Unit</b>	<b>SDT-600</b>
Motor	HP	1
Air Speed	M/Sec	4.6
Air Delivery	M <sup>3</sup> /Min	22
CFM	Ft <sup>3</sup> /Min	780
Filter Area	M <sup>2</sup>	2.1
Space Occupied	CM	80 x 80 x 92.2
Packing Size	CM	67 x 68 x 55 (Blower) 90.5 x 61.5 x 19 (Accessory)
N.W.	KGS	44 (Blower) 39 (Accessory)
G.W.	KGS	46 (Blower) 41 (Accessory)

\*Importer: \_\_\_\_\_.

### Table Content

- 1.General safety rules
- 2.Additional safety rules for Down-Draft Table
- 3.Unpacking and assembly
- 4.The application of this machine
- 5.Explanation of symbols used on machine
- 6.Handling and transportation
- 7.Electrical connection / disconnection
- 8.Noise declaration
- 9.Operation
- 10.Assembly drawing

## **1. General safety rules**

"WARNING! When using electric tools basic safety precautions should always be followed to reduce the risk of fire, electric shock and personal injury, including the following.

Read all these instructions before attempting to operate this product and save these instructions".

- 1- Keep work area clear
  - Cluttered areas and benches invite injuries.
- 2- Consider work area environment
  - Do not expose tools to rain.
  - Do not use tools in damp or wet locations.
  - Keep work area well lit.
  - Do not use tools in the presence of flammable liquids or gases.
- 3- Guard against electric shock
  - Avoid body contact with earthed or grounded surfaces.
- 4- Keep other persons away
  - Do not let persons especially children, not involved in the work touch the tool or the extension cord and keep them away from the work area.
- 5- Store idle tools
  - When not in use, tools should be stored in a dry locked-up place, out of reach of children.
- 6- Do not force the tool
  - It will do the job better and safer at the rate for which it was intended.
- 7- Use the right tool
  - Do not force small tools to do the job of a heavy-duty tool.
  - Do not use tools for purposes not intended; for example do not use circular saws to cut tree limbs or logs.
- 8- Dress properly
  - Do not wear loose clothing or jewelry, they can caught in moving parts.
  - Non-skid footwear is recommended when working outdoors.
  - Wear protective hair covering to contain long hair.
- 9- Use protective equipment
  - Use safety glasses.
  - Use face or dust mask if cutting operations create dust.
- 10- Connect dust extraction equipment
  - If devices are provided for the connection of dust extraction and collecting equipment, ensure these are connected and properly used.
- 11- Do not abuse the cord
  - Never yank the cord to disconnect it from the socket. Keep the cord away from heat, oil and sharp edges.
- 12- Secure work
  - Where possible use clamps or a vice to hold the work. It is safer than using your hand.

- 13- Do not overreach
  - Keep proper footing and balance at all times.
- 14- Maintain tools with care
  - Keep cutting tools sharp and clean for better and safer performance.
  - Follow instructions for lubricating and changing accessories.
  - Inspect tool cords periodically and if damaged have them repaired by an authorized service facility.
  - Inspect extension cords periodically and replace if damaged.
  - Keep handles dry, clean and free from oil and grease.
- 15- Disconnect tools
  - When not in use, before servicing and when changing accessories such as blades, bits and cutters, disconnect tools from the power supply.
- 16- Remove adjusting keys and wrenches
  - Form the habit of checking to see that keys and adjusting wrenches are removed from the tool before turning it on.
- 17- Avoid unintentional starting
  - Ensure switch is in "off" position when plugging in.
- 18- Use outdoor extension leads
  - When the tool is used outdoors, use only extension cords intended for outdoor use and so marked.
- 19- Stay alert
  - Watch what you are doing, use common sense and do not operate the tool when you are tired.
- 20- Check damaged parts
  - Before further use of tool, it should be carefully checked to determine that it will operate properly and perform its intended function.
  - Check for alignment of moving parts, binding of moving parts, breakage of parts, mounting and any other conditions that may affect its operation.
  - A guard or other part that is damaged should be properly repaired or replaced by an authorized service center unless otherwise indicated in this instruction manual.
  - Have defective switches replaced by an authorized service center.
  - Do not use the tool if the switch does not turn it on and off.
- 21- Warning
  - The use of any accessory or attachment other than one recommended in this instruction manual may present a risk of personal injury.
- 22- Have your tool repaired by a qualified person
  - This electric tool complies with the relevant safety rules. Repairs should only be carried out by qualified persons by using original spare parts; otherwise this may result in considerable danger to the user.

## **2. Additional Safety Rules for dust collectors**

Woodworking can be dangerous if safe and proper operating procedures are not followed. As with all machinery, there are certain hazards involved with the operation of the product. Using the machine with respect and caution will considerably lessen the possibility of personal injury. However, if normal safety precautions are overlooked or ignored, personal injury to the operator may result. Safety equipment such as guards, push sticks, hold-downs, feather boards, goggles, dust masks and hearing protection can reduce your potential for injury. But even the best guard won't make up for poor judgment, carelessness or inattention. Always use common sense and exercise caution in the workshop. If a procedure feels dangerous, don't try it. Figure out an alternative procedure that feels safer. **REMEMBER:** Your personal safety is your responsibility.

1. **READ** and understand instruction literature before operating product.
2. **FOLLOW** all local electrical and safety codes, as well as some relevant European standards (EN 60204). All electrical connections and wiring should be performed by qualified personnel only.
3. **MAKE SURE** vacuum hose is connected to dust intake port before operating machine.
4. **TO AVOID** electrical shock, do not expose to rain or use in damp locations. Store machine indoors. Use for dry pick-up only.
5. **DO NOT** operate near flammable products. Sparks can ignite vapors from flammable products and cause **EXPLOSION**.
6. **COLLECT** wood materials only. Combining metal shavings/dust with wood dust can create a **FIRE** hazard.
7. **UNPLUG** machine from power source before servicing, changing bags, unclogging or cleaning unit.
8. **DUST** generated by certain woods and wood products can be hazardous to your health. **ALWAYS** wear eye protection and use face or dust mask in dust-laden environments.
9. **REPLACE** or repair damaged or worn cord immediately.
10. **PROTECT** the power cable and never allow the cable to come in contact with sharp objects.
11. **DO NOT** kink power cable and never allow the cable to come in contact with oil, grease, hot surfaces or chemicals.
12. **MAKE CERTAIN** that the power source conforms to the requirements of your equipment.
13. **THERE** is a high speed blower wheel inside the blower housing that can amputate fingers, grab loose clothes or neckties. **DO NOT** insert fingers or any foreign object into the dust intake port.
14. **ALWAYS** cover individual dust intake ports when not in use.

### **3. Unpacking and assembly**

- <1> Unpack the shipping container with care.
- <2> Check nothing missing for the component listed in the table of assembly drawing.
- <3> Assemble the dust collector by following the drawing of the assembly draw.
- <4> Contact local agent for any problem of assembly and missing part.



**Warning!** Do not connect the dust collector to the power source until machine is completely assembled and you have read and understand the entire instruction manual.

**Note:** The drawing for proper assembly and mechanical component part list is provided as part 11.

### **4. The application of this machine**

- a) Purpose of this machine: Basically this dust collector was designed to be connected to the wood-working machine so as to collect the wood chip produced during operation.
- b) The following items are prohibited for this machine.
  - operating machine without going through this manual.
  - operating machine without making sure that every safety precaution is well according to this instruction.

### **5. Explanation of symbols used on machine**

Warning of Electric Shock	Warning of not to touch rotational fan	Caution of read instruction
	 Do not access to the rotational fan.	 Please see instruction manual before operation.

### **6. Handling and transportation**

The net weight of this machine is approximately 83 kgs. It can be handled and transported without the help of lifting tools.

### **7. Electrical connection / disconnection**

- <1> Electrical connection:
  - a. The hand-operated power disconnection device or the plug is recommended to be provided before the connection of power supply.
  - b. For the protection of control device, we recommend the operator to supply **a fuse with appropriate current rating**, and the total length between fuse and connection terminal shall not exceed 1.5 m.

<2> Electrical disconnection:

- a. The disconnection is carried out by hand-operated disconnecting device.
- b. Be sure to disconnect this machine from power source, when you want to stop the job, maintenance, and adjustment.

<3> Grounding.

The grounding of this model is carried out **by connecting the yellow/green terminal of supply cable** to the grounding terminal of power source. Be sure to ground your machine before connecting machine to power source in any situation.

**<WARNING!> Do not disconnect grounding terminal before disconnecting power source.**

<4> Electric installation & storage conditions.

Electrical equipment is constructed for the following conditions. If the operation beyond the conditions described as the followings is required, the assessment to keep electrical equipment in a good and safe performance is necessary.

- (1) Ambient air temperature : + 5 ? ~ + 55 ? in free air, and the average ambient air temperature over a period of 24 hours shall not exceed + 50 ? .
- (2) Humidity : 30 % ~ 95 %.
- (3) Altitude : up to 1000 m above mean sea level.
- (4) Transportation & storage condition: - 25 ? ~ + 55 ? , and for short periods not exceeding 24 hours at up to + 70 ? .

<5> Electrical circuit diagram.

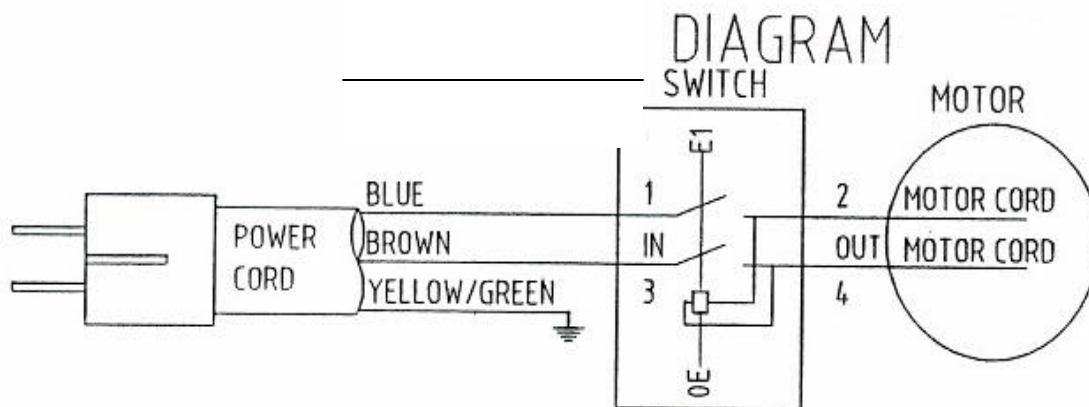

## **8. Noise declaration**

“The figures quoted are emission levels and are not necessarily safe working levels. Whilst there is a correlation between the emission and exposure levels, this cannot be used reliably to determine whether or not further precautions are required. Factors that influence the actual level of exposure of the work force include the characteristics of the work room, the other sources of noise, etc, i.e. the number of machines and other adjacent processes. Also the permissible exposure level can vary from country to country. This information, however, will enable the user of the machine to make a better evaluation of the hazard and risk”.

Based on the statement as mentioned above, the noise level for this model is about 75 dB(A).

## **9. Operation**

- <1> In order to ensure the good performance of dust collection, be sure to check the appropriate air delivery capacity of downdraft table according to the requirement specified for the working machine.
- <2> After the proper connection of downdraft table and machine, connect the power according to the instructions of part 7. While not use, the disconnection shall be done according to also the instructions of part 7.
- <3> This downdraft table is switched ON/OFF by pushing the I/O push buttons. During normal operation, always operate this downdraft table through these two buttons.

# 10. Assembly Drawing

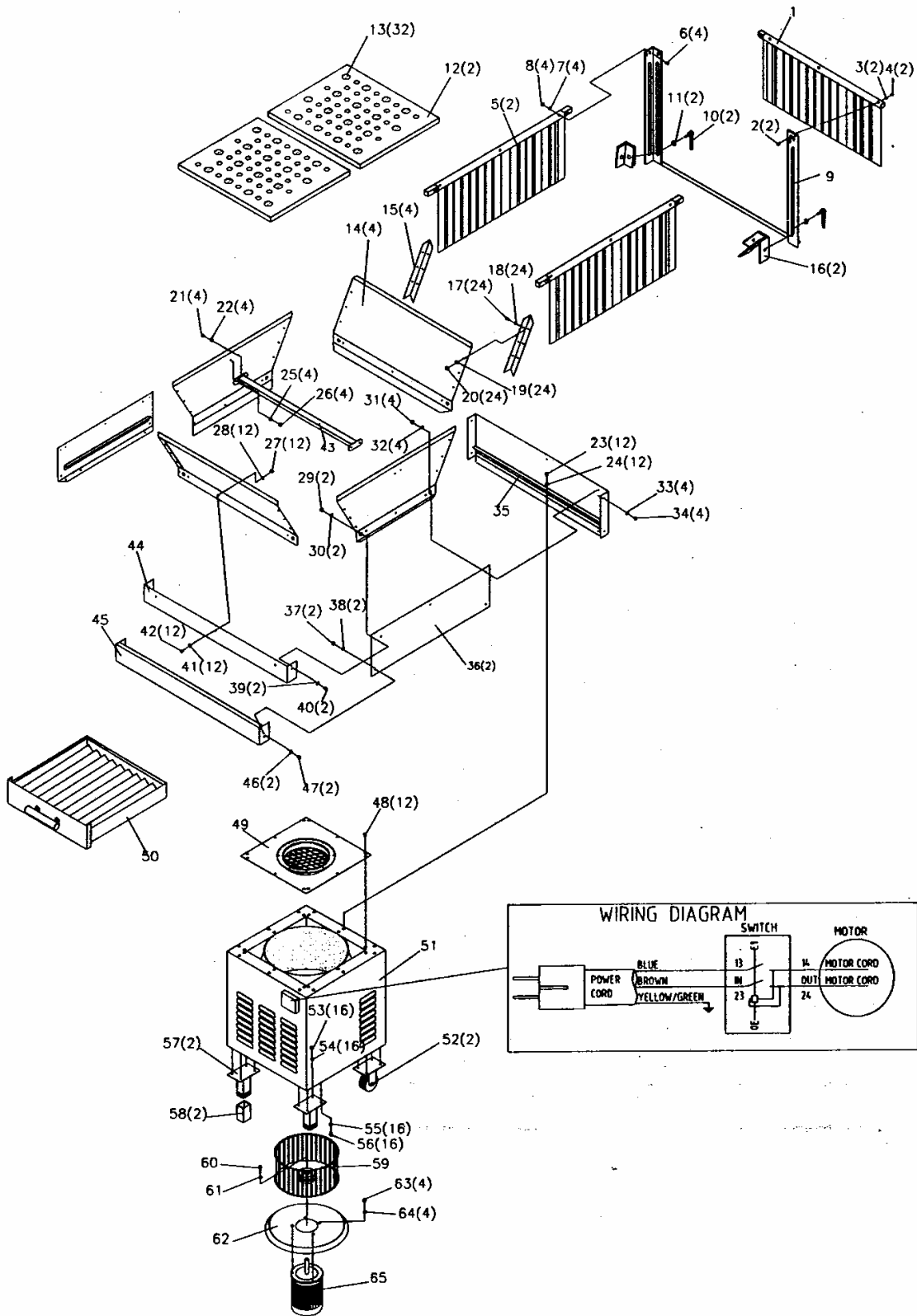

PART NO.	PART NAME	Q'TY
1	CURTAIN (BACK)	1
2	1/4" x 7/8" HEX HD SCR	2
3	1/4" FLAT WASHER	2
4	1/4" HEX NUT	2
5	CURTAIN (SIDE)	2
6	1/4" x 7/8" HEX HD SCR	4
7	1/4" FLAT WASHER	4
8	1/4" HEX NUT	4
9	CURTAIN FRAME	1
10	5/16" x 1" SPECIAL SCR	2
11	5/16" FLAT WASHER	2
12	TABLE BOARD	2
13	GASKET	32
14	SKEW BOARD	4
15	SKEW BOARD FIRM PLATE	4
16	CURTAIN FRAME PLATE	2
17	1/4" x 5/8" HEX HD SCR	24
18	1/4" FLAT WASHER	24
19	1/4" FLAT WASHER	24
20	1/4" HEX NUT	24
21	1/4" x 5/8" HEX HD SCR	4
22	1/4" FLAT WASHER	4
23	1/4" x 5/8" HEX HD SCR	12
24	1/4" FLAT WASHER	12
25	1/4" FLAT WASHER	4
26	1/4" HEX NUT	4
27	1/4" HEX NUT	12
28	1/4" FLAT WASHER	12
29	1/4" HEX NUT	2
30	1/4" FLAT WASHER	2
31	1/4" HEX NUT	4
32	1/4" FLAT WASHER	4
33	1/4" FLAT WASHER	4

PART NO.	PART NAME	Q'TY
34	1/4" x 5/8" HEX HD SCR	4
35	MIDDLE BOARD (BACK)	1
36	MIDDLE BOARD (SIDE)	2
37	1/4" HEX NUT	2
38	1/4" FLAT WASHER	2
39	1/4" FLAT WASHER	2
40	1/4" x 5/8" HEX HD SCR	2
41	1/4" FLAT WASHER	12
42	1/4" x 5/8" HEX HD SCR	12
43	BOARD SUPPORT	1
44	MIDDLE (UP)	1
45	MIDDLE (DOWN)	1
46	1/4" FLAT WASHER	2
47	1/4" x 5/8" HEX HD SCR	2
48	M 4.2 x 12mm PAN HD SC	12
49	SAFTY NET	1
50	FILTER DRAWER	1
51	CASE	1
52	CASTER	2
53	1/4" HEX NUT	16
54	1/4" FLAT WASHER	16
55	1/4" FLAT WASHER	16
56	1/4" x 5/8" HEX HD SCR	16
57	TABLE FOOT	2
58	FOOT GASKET	2
59	FAN	1
60	5/16" x 3/4" HEX HD SCR	1
61	5/16" FLAT WASHER	1
62	DEFLECTOR	1
63	1/4" HEX NUT	4
64	1/4" FLAT WASHER	4
65	MOTOR	1