

OSKAR Welding Fume Extractor

General Safety Information

MACHINE WARNING SIGNS

▲ DANGER Indicates an imminently hazardous situation which, if not avoided, will result in death or serious injury.

▲ WARNING Indicates a potentially hazardous situation which, if not avoided, could result in death or serious injury.

▲ CAUTION Indicates a potentially hazardous situation which, if not avoided, may result in minor or moderate injury.
Used without the safety alert symbol (▲) indicates potentially hazardous situation which, if not avoided, may result in property damage.



Warning of electric shock



Do not expose the equipment to rain or use in damp locations.



Figure 1



Do not use the equipment around flammable products, if not avoided, sparks can ignite vapors from flammable products. Read and understand all warnings and operating instructions before using this equipment. Failure to follow all instructions may result in electric shock, fire, and/or serious personal injury or property damage.

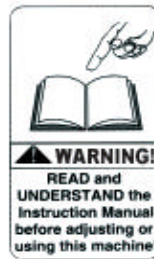

Please read and save these instructions. Read carefully before attempting to assemble, install, operate or maintain the product described. Protect yourself and others by observing all safety information. Failure to comply with instructions could result in personal injury and/or property damage! Retain instructions for future reference.



OSKAR Welding Fume Extractor

TABLE OF CONTENT

MACHINE WARNING SIGNS	1
Specifications	2
ADDITIONAL SAFETY RULES FOR AIR CLEANERS.....	4
EC DECLARATION OF CONFORMITY	5
Assembly	6
ELECTRICAL CONNECTION / DISCONNECTION	7
Operation	7
Dimensions of Covers and Supports	10
BRACKET ASSEMBLY ILLUSTRATION	11
Repair Parts Illustration	13
Repair Parts List	15

Specifications

Motor	3/4HP (560 W)
Air Volume (C.F.M.)	(Low) 1000 Ft ³ /Min
.....	(Medium) 1400 Ft ³ /Min
.....	(High) 1800 Ft ³ /Min
Packing Size (L x W x H)	26.6" x 26" x 36.5" (67.5 x 66 x 92.7 cm)
Net Weight	193 lbs (87.5 kgs)
Gross Weight	204 lbs (92.5 kgs)
Timer Setting	1/2, 1, 2, or 4 hours (up to 7.5 hr)
Remote Control	On/Off, Timer, Speed
Sound Level	71 dB(A)

Please read and save these instructions. Read carefully before attempting to assemble, install, operate or maintain the product described. Protect yourself and others by observing all safety information. Failure to comply with instructions could result in personal injury and/or property damage! Retain instructions for future reference.



www.oskarsales.com



SMT-080122

OSKAR Welding Fume Extractor

General Safety Information

(Continued)



Use this product carefully to

effectively avoid any possible danger. Observe the following safety regulations to avoid bodily injury due to electrocution during use.

Air Cleaner can be dangerous if safe and proper operating procedures are not followed. As with all machinery, there are certain hazards involved with the operation of the product. Using the machine with respect and caution will considerably lessen the possibility of personal injury. However, if normal safety precautions are overlooked or ignored, personal injury to the operator may result. Safety equipment such as guards, push sticks, hold-downs, featherboards, goggles, dust masks and hearing protection can reduce your potential for injury. But even the best guard won't make up for poor judgment, carelessness or inattention. Always use common sense and exercise caution in the workshop. If a procedure feels

dangerous, don't try it. Figure out an alternative procedure that feels safer.

REMEMBER: Your personal safety is your responsibility. For additional information please visit our website www.oskarsales.com.



This machine was designed for

certain applications only. OSKAR strongly recommends that this machine not be modified and/or used for any application other than that for which it was designed. If you have any questions relative to a particular application, DO NOT use the machine until you have first contacted OSKAR to determine if it can or should be performed on the product.



Failure to follow these rules may

result in serious personal injury.

1. **For your own safety, read and understand the instruction manual**

Please read and save these instructions. Read carefully before attempting to assemble, install, operate or maintain the product described. Protect yourself and others by observing all safety information. Failure to comply with instructions could result in personal injury and/or property damage! Retain instructions for future reference.



OSKAR Welding Fume Extractor

before operating the unit. Learn the unit's application and limitations as well as the specific hazards peculiar to it.

2. **Keep work area clean.** Cluttered areas and benches invite accidents.
3. **Don't use in dangerous environment.** Don't use this unit in damp or wet locations, or expose it to rain. Keep work area well-lighted.
4. **Keep children and visitors away.** All children and visitors should be kept a safe distance from work area.
5. **Disconnect unit** before servicing.
6. **Check damaged parts.** Before further use of the unit, properly repair or replace any part that is damaged.

ADDITIONAL SAFETY RULES FOR AIR CLEANERS

⚠ WARNING *Failure to follow these rules may result in serious injury.*

⚠ DANGER *Do not use this unit to filter metal dust. Combining wood and metal dust can create an explosion or fire hazard. This*

unit is intended to filter nonexplosive atmospheres only.

⚠ WARNING *Do not use this unit to dissipate fumes or smoke. Explosions or fire can result. This air cleaner is intended for use where only dry airborne dust is present. Its use should be limited to nonexplosive, nonmetallic atmospheres.*

1. Do not operate this unit until it is completely assembled and installed according to the instructions. A unit incorrectly assembled can cause injury.
2. Obtain advice from your supervisor, instructor, or an other qualified person if you are not thoroughly familiar with the operation of this unit. Knowledge is safety.
3. Follow all wiring codes and recommended electrical connections to prevent electrical shock or electrocution.
4. Do not lift this unit by the power cord. Do not use the power cord as a hanging device. A damaged power cord can cause electrical shock or electrocution.
5. Securely anchor this unit to a permanent



OSKAR Welding Fume Extractor

or fixed supporting structure when suspending it from the ceiling. A falling unit can cause serious injury. Always keep a minimum of 7 feet between the bottom of the unit and the floor surface to allow for sufficient head clearance. Use only a chain rated for a minimum of 410 lb. working load to adequately hold the unit. Use steel S-Hooks that are at least 5/16" in diameter to suspend the unit from the ceiling. Lag-type bolts used to suspend the unit from the ceiling must be threaded at least 1½" into supporting structural members.

6. Support this unit or securely clamp it to the work surface when it is used in a portable application to eliminate potential injury and/or damage to the unit.
7. Ensure that the intake and exhaust areas are clear prior to starting the unit. Clogged intakes or exhausts can cause an explosion and/or fire.
8. Keep arms, hands, and fingers away from the fan. Avoid all exposure to rotating parts to prevent injury.
9. Do not operate this unit without the filters in place. Dust and other small

debris will go directly to the motor, causing overheating and the potential for fire and/or explosion.

10. Do not attempt to remove or replace the filter(s) while the unit is running. Exposed fan blades can cause severe cuts. Make certain that the unit is disconnected from the power source.
11. Maintain the unit in top condition. Clogged filters can increase the potential for fire or explosion. Follow all instructions for changing and cleaning filters.
12. Store the unit in a location that eliminates the potential for damage to the power cord. A damaged power cord can cause shock or electrocution. Safely store power cord on the unit to eliminate tripping hazards.
13. Turn the unit "off" and disconnect the unit from the power source before installing or removing accessories, before adjusting or changing set-ups, or when making repairs. An accidental start-up can cause serious injury.

EC DECLARATION OF CONFORMITY

Provided that it is used and maintained in



OSKAR Welding Fume Extractor

accordance with the generally accepted codes of good practice and the recommendations of the instruction manual, meets the essential safety and health requirements of the Machinery Directive, EMC Directive, and the EC Low Voltage Directive.

According to the following ECDirective:

- Machinery Directive98/37/EEC
- EMC Directive89/336/EEC
- Low Voltage Directive73/23/EEC

For the most specific risks of this machine, safety and compliance with the essential requirements of the Directive has been based on elements of:

- The European Standard EN 292-1 : 1991 - Safety of machinery – Basic concepts, general principles for design – Part 1: Basic terminology, methodology.
- The European Standard EN 292-2 : 1991 - Safety of machinery – Basic concepts, general principles for design – Part 2: Technical principles and specifications.
- The European Standard EN 60204-1 : 1997 - Safety of machinery – Electrical equipment of machines –

Part 1: General requirements.

- The European Standard EN 55014 : 1993 – Limits and methods of measurement of radio interference characteristics of electrical motor operated and thermal appliance for household and similar purpose electrical tools and similar electric apparatus.

Assembly

Assemble the industrial air cleaner by following the illustration on page 13. Contact local agent for any problem of assembly or missing parts.

⚠ WARNING *Do not connect the air cleaner to the power source until machine is completely assembled and you have read and understand the entire instruction manual.*

NOTE: See page 13 for mechanical component parts list. Assemble the supports by following bracket assembly illustration on page 11-12. Contact local agent for any problem of assembly or

OSKAR Welding Fume Extractor

missing parts.

ELECTRICAL CONNECTION / DISCONNECTION

ELECTRICAL CONNECTION

1. The hand-operated power disconnection device or the plug is recommended to be used before connection of power supply.
2. For the protection of control device, we recommend the operator to supply a fuse with appropriate current rating, and the total length between fuse and connection terminal not to exceed 5 feet.

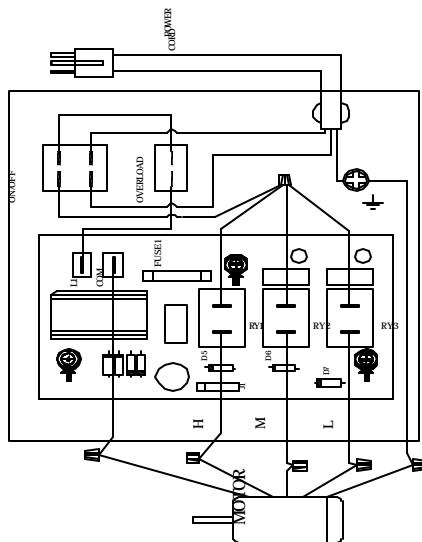

Figure 2 – Electrical Circuit Diagram

ELECTRICAL DISCONNECTION

1. The disconnection is carried out by hand-operated disconnecting device.
2. Be sure to disconnect this machine from power source when you want to stop the job for maintenance and adjustment.

GROUNDING

The grounding of this model is carried out by connecting the yellow/green terminal of supply cable to the grounding terminal of power source. Be sure to ground your machine before connecting machine to power source in any situation.

⚠ WARNING

Do not disconnect grounding terminal before disconnecting power source.

Operation

1. After the proper connection of the machine, connect the power according to the instructions in "Assembly" section above. While not in use, the disconnection shall also be done according to the instructions in "Assembly" section above.
2. In order to ensure the good performance,

OSKAR Welding Fume Extractor

be sure to check the appropriate air delivery capacity of air cleaner according to the requirement specified for the working machine.

Unpacking

The machine should be unpacked carefully. Check if the machine and components are consistent with those indicated in the Parts List. If any doubt arises or when the components are incomplete, contact your dealer.

OSKAR Welding Fume Extractor

Dimensions (in inches)

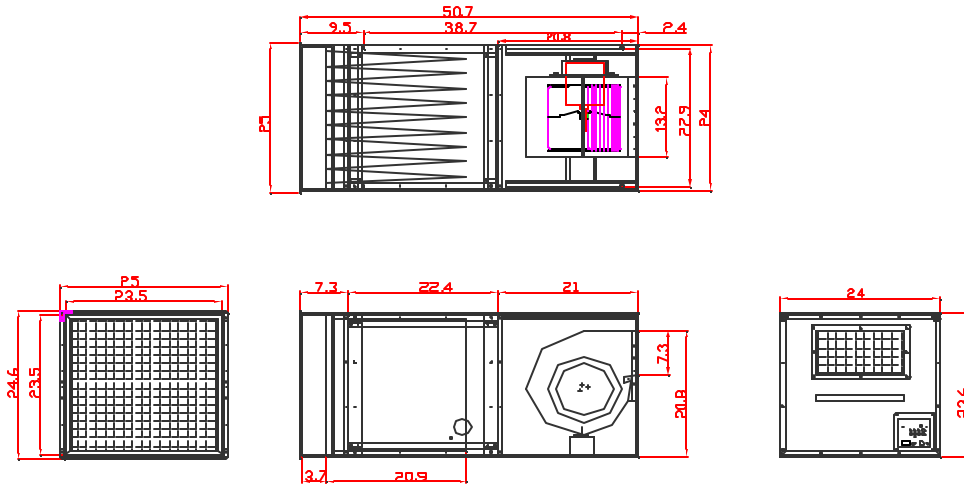

Dimensions (in mm)

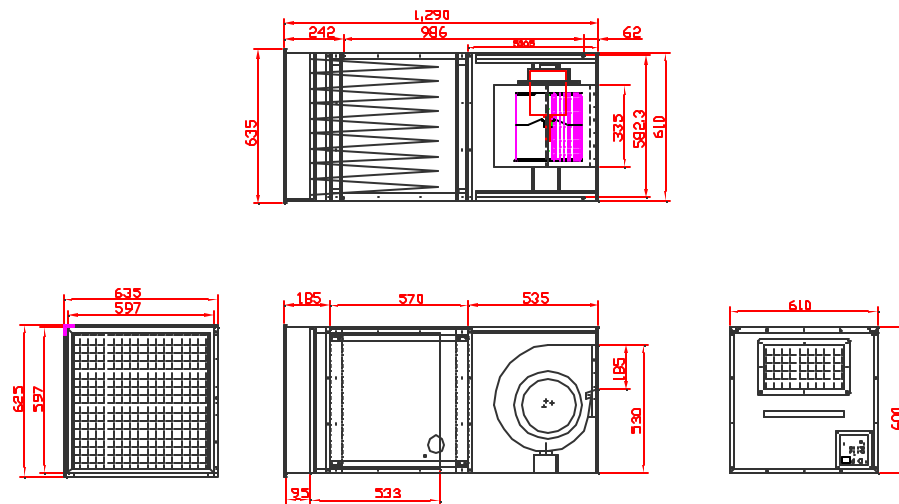

OSKAR Welding Fume Extractor

Dimensions of Covers and Supports

(in inches)

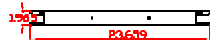

A. 23.659" x 1.965" x 4 pcs



B. 22.401" x 1.965" x 4 pcs

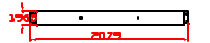

C. 20.79" x 1.965" x 4 pcs

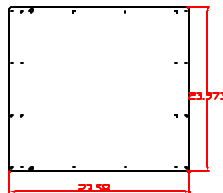

D. 23.59" x 23.973" x 1 pc

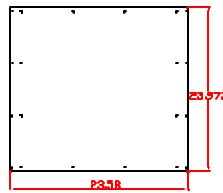

E. 23.59" x 23.973" x 1 pc

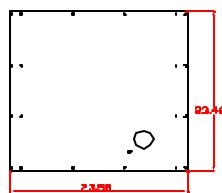

F. 23.58" x 23.462" x 1 pc

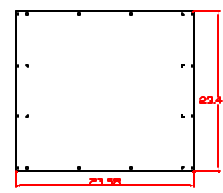

G. 23.58" x 23.462" x 1 pc

** Round Phillips Head Screw #10x1/2"x112 pcs
 ** Hanger 5/16"x4 pcs, Hex Nut 5/16"x4 pcs

(in mm)

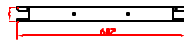

A. 602mm x 50mm x 4 pcs



B. 570mm x 50mm x 4 pcs



C. 529mm x 50mm x 4 pcs

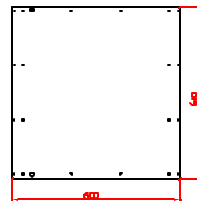

D. 600mm x 610mm x 1 pc

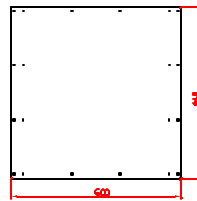

E. 600mm x 610mm x 1 pc

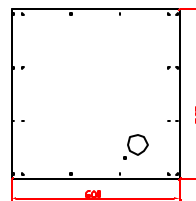

F. 600mm x 597mm x 1 pc

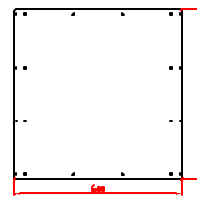

G. 600mm x 597mm x 1 pc

** Round Phillips Head Screw #10x1/2" x 112 pcs
 ** Hanger 5/16" x 4 pcs, Hex Nut 5/16" x 4 pcs

OSKAR Welding Fume Extractor

BRACKET ASSEMBLY ILLUSTRATION

1.

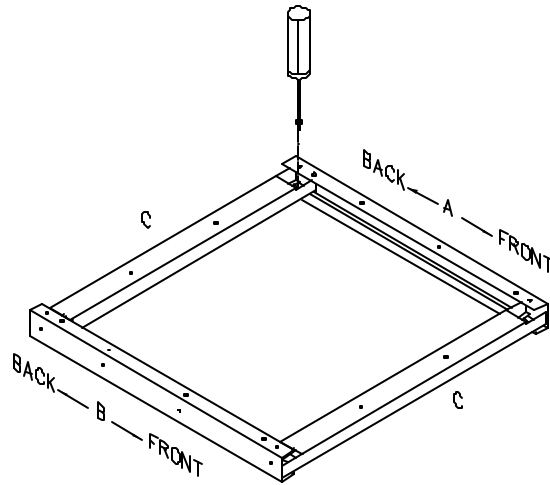

2.

OSKAR Welding Fume Extractor

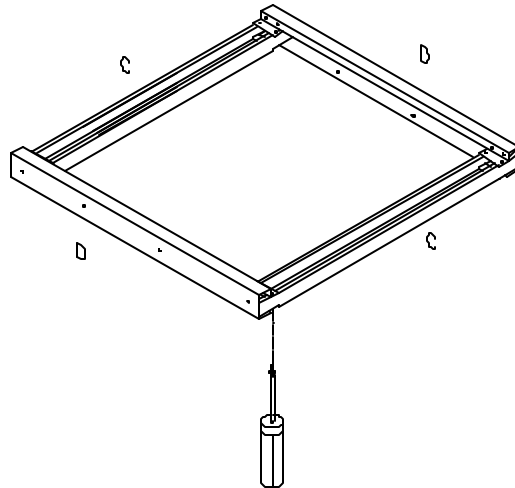

3.

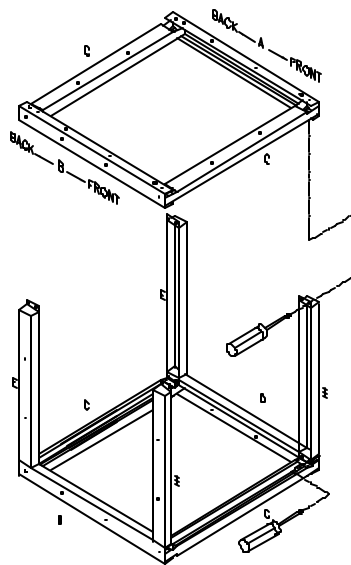

4.

OSKAR Welding Fume Extractor

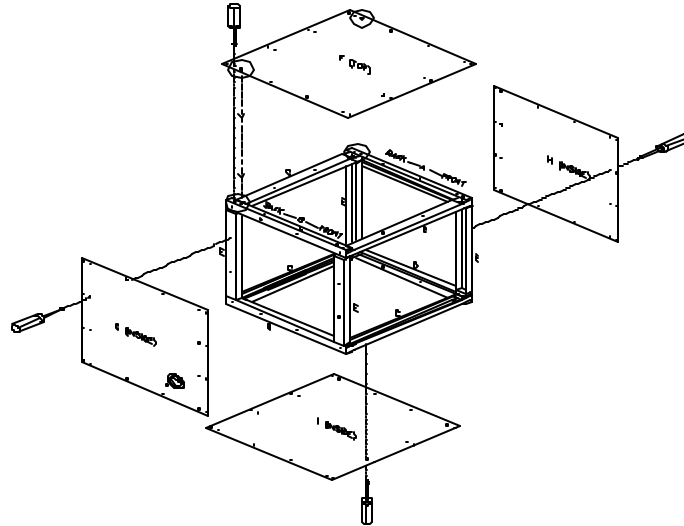

Repair Parts Illustration

For Repair Parts, call 1-919-570-2862

24 hours a day – 365 days a year

Please provide following information:

- Model number
- Serial number (if any)
- Part description and number as shown in parts list

OSKAR Welding Fume Extractor

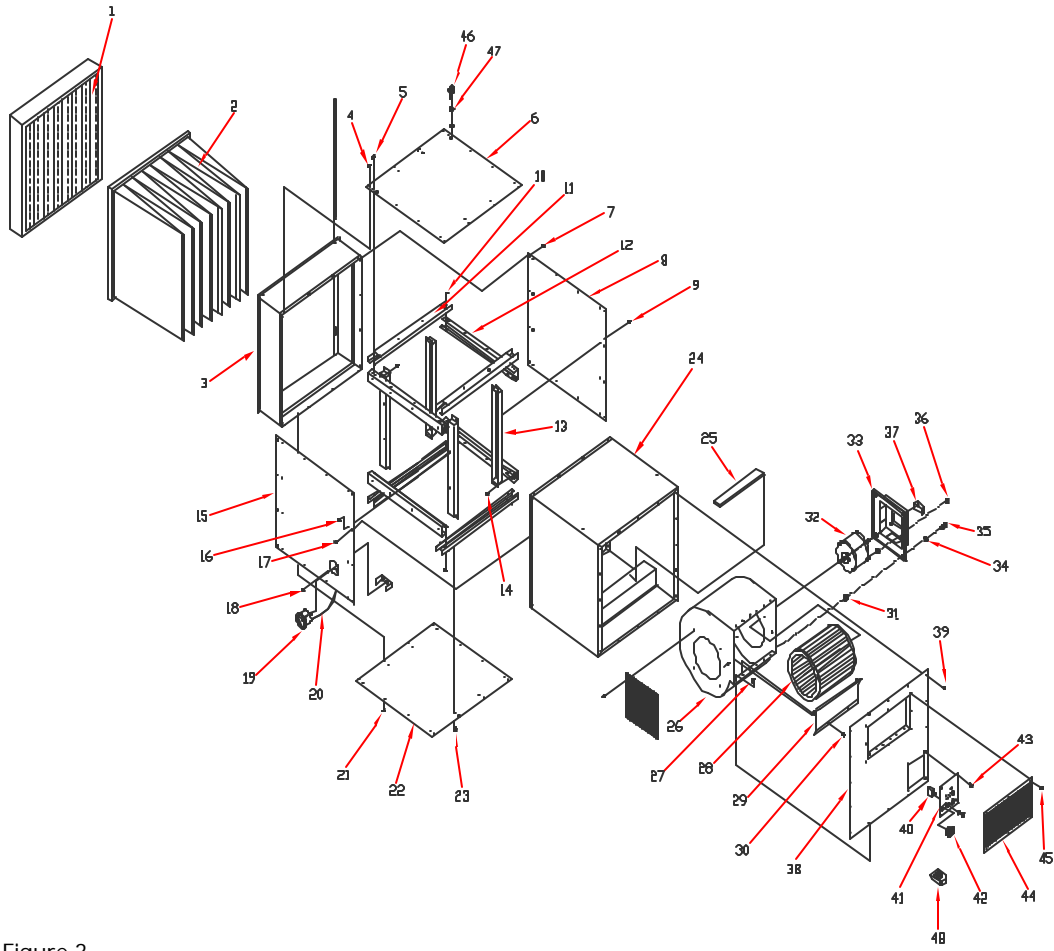

Figure 3

OSKAR Welding Fume Extractor

Repair Parts List

Repair Parts List for Industrial Air Cleaner

Reference Number	Description	Part Number	Quantity
1	Pleated Filter	6B590	1
2	8-Pocket Bag Filter	HV30001	1
3	Frame	HV30002	1
4	#10 x 1/2" Round Phillips Head Screw	HV30003	8
5	#10 x 1/2" Round Phillips Head Screw	HV30003	12
6	Cover (Upper)	HV30004	1
7	#10 x 1/2" Round Phillips Head Screw	HV30003	8
8	Cover (Back)	HV30005	1
9	#10 x 1/2" Round Phillips Head Screw	HV30003	12
10	#10 x 1/2" Round Phillips Head Screw	HV30003	16
11	Support - C	HV30006	4
12	Support - B Assembly (bracket A, B, D, and D)	HV30007	4
13	Support - E	HV30008	4
14	#10 x 1/2" Round Phillips Head Screw	HV30003	16
15	Cover (Front)	HV30009	1
16	#10 x 1/2" Round Phillips Head Screw	HV30003	12
17	#10 x 1/2" Round Phillips Head Screw Manometer Assembly (#18 – 20)	HV30003 HV30010	8
18	Hex Nut	*	1
19	Manometer	*	1
20	Tubing	*	1

OSKAR Welding Fume Extractor

Reference Number	Description	Part Number	Quantity
21	#10 x 1/2" Round Phillips Head Screw	HV30003	8
22	Cover (Lower)	HV30011	1
23	#10 x 1/2" Round Phillips Head Screw	HV30003	12
24	Machine Body	HV30012	1
25	Foam Tape	**	1
26	Blower	HV30013	1
27	#10 x 1/2" Round Phillips Head Screw	HV30003	18
28	Impeller	HV30014	1
	Blower Cover Assembly (#29 – 30)	HV30015	
29	Blower Cover	*	1
30	#10 x 1/2" Round Phillips Head Screw	*	4
31	Anti-Vibration Bolt	HV30016	4
	Motor Assembly (#32 – 37)	HV30017	
32	Motor	*	1
33	Motor Base	*	1
34	Hex Screw	*	4
35	Flat Washer	*	4
36	Flange Nut	*	8
37 ▲	Capacitor	HV30026	1
38	Discharge Cover	HV30018	1
39	#10 x 1/2" Round Phillips Head Screw	HV30003	14
40	Overload Protector	HV30019	1
41	Control Panel (Line Cord included)	HV30020	1
42	Switch	HV30021	1
43	#10 x 1/2" Round Phillips Head Screw	HV30003	4

OSKAR Welding Fume Extractor

Reference Number	Description	Part Number	Quantity
44	Screen	HV30022	1
45	#10 x 1/2" Round Phillips Head Screw	HV30003	8
46	Eyebolt	HV30023	4
47	Hex Nut	HV30024	4
48	Remote Control	HV30025	1

(*) Available only as part of assembly.

(**) Hardware item available locally.

(▲) Available with Motor Assembly or ordered separately.